

Dihydropteridine Reductase Deficiency in Man: From Biology to Treatment

Alberto Ponzone, Marco Spada, Silvio Ferraris, Irma Dianzani, Luisa de Sanctis

Department of Pediatrics, University of Torino, Italy

DOI 10.1002/med.10055



Abstract: In 1975, dihydropteridine reductase (DHPR) deficiency was first recognized as a cause of tetrahydrobiopterin (BH₄) deficiency, leading to hyperphenylalaninemia (HPA) and impaired biogenic amine deficiency. So far, more than 150 patients scattered worldwide have been reported and major progresses have been made in the understanding of physiopathology, screening, diagnosis, treatment, and molecular genetics of this inherited disease. Present knowledge on different aspects of DHPR deficiency, largely derived from authors' personal experience, is traced in this article. © 2003 Wiley Periodicals, Inc. *Med Res Rev*, 24 No. 2, 127–150, 2004

Key words: tetrahydrobiopterin deficiency; neonatal screening; hyperphenylalaninemia; biogenic amine deficiency

1. INTRODUCTION

Tetrahydrobiopterin (BH₄) deficiencies represent a heterogeneous group of disorders because of inborn errors in the cofactor biosynthetic or regenerative pathways. Our knowledge about their natural course, biochemistry, diagnosis, screening, treatment, and molecular genetics was largely expanded during the last decades. More than 400 patients scattered worldwide are presently included in two international databases,^{1,2} BIODEF (patients database, <http://www.bh4.org/biodef1.html>) and BIOMDB (mutations database, <http://www.bh4.org/biomdb1.html>). Since neonatal hyperphenylalaninemia (HPA) is the most obvious marker of BH₄ deficiency, and most of developed countries have programs of mass screening for phenylketonuria (PKU), the confirmation of diagnosis may include a systematic search for this rare condition, because the prognosis and treatment are totally different from the phenylalanine-4-hydroxylase (PAH) apoenzyme deficiency. Dihydropteridine reductase (DHPR) deficiency, the first recognized enzyme defect, is the second most frequent cause of BH₄ deficiency (see Fig. 1).

Correspondence to: Prof. Alberto Ponzone, Department of Pediatrics, University of Torino, Piazza Polonia, 94, 10126 Torino, Italy.
E-mail: alberto.ponzone@unito.it

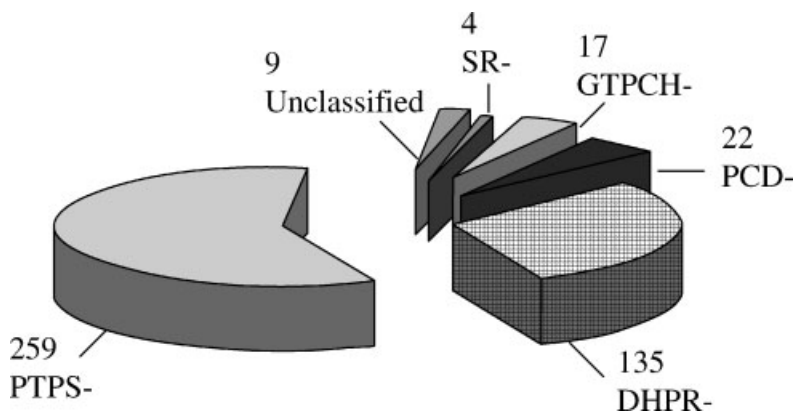

Figure 1. Numbers of patients suffering from tetrahydrobiopterin (BH₄) deficiency included in the BIODF database.¹ DHPR⁻, dihydropteridine reductase deficiency; GTPCH I⁻, guanosine triphosphate cyclohydrolase I deficiency; PCD⁻, carbinolamine dehydratase deficiency; PTPS⁻, 6-pyruvoyl-tetrahydropterin synthase deficiency; SR⁻, sepiapterin reductase deficiency.

2. BH₄ FUNCTIONS AND DEFICIENCY

BH₄ is best recognized as the essential, non-protein cofactor for the aromatic amino acid hydroxylases, the rate-limiting enzymes in phenylalanine (Phe), tyrosine (Tyr), and tryptophan (Trp) catabolism and in biosynthesis of the neurotransmitters dopamine and serotonin. Moreover, it serves as the cofactor for the three isoforms of nitric oxide synthase and for glyceryl ether mono-oxygenase in alkyl-ether metabolism.³ Every cell or tissue of higher organisms possibly contains BH₄, which additionally appears to be involved in other metabolic and cellular functions. It has been previously shown that BH₄ is a growth factor for *Crithidia fasciculata*, a property utilized in the past for measuring bipterins in body fluids,⁴ and more recently that it enhances the proliferative activity of hemopoietic and leukemic cells.⁵ Another cellular function of BH₄ in neurons is the enhancement of the release of dopamine and serotonin,⁶ whereas its role in neuroprotection is still controversial.⁷

Despite this widespread involvement in various biological processes, however, the profound pathogenic effect exerted by BH₄ deficiency in man is essentially dependent on the impaired hydroxylation of aromatic amino acids, leading to HPA and impaired dopamine and serotonin biosynthesis. Since HPA is its most obvious biochemical marker, this condition was originally confused with PAH deficiency, and considered an “atypical” or “malignant” form of PKU, owing to the worse prognosis despite early diagnosis and dietary treatment.^{8,9} Five molecular diseases leading to BH₄ deficiency, however, have been identified during the last 30 years, in the pathways of cofactor *de novo* synthesis or regeneration (see Figs. 2 and 3). The deficiency of guanosine triphosphate cyclohydrolase I (GTPCH), the first enzyme in the biosynthetic pathways of BH₄, was described in 1984 in a Spanish girl,¹⁰ and in the same year defective 6-pyruvoyl-tetrahydropterin synthase (PTPS) activity was detected in an Italian patient.¹¹ The latter enzyme, originally called phosphate eliminating enzyme,¹² is essential for the conversion of dihydroneopterin triphosphate into PTP. In 1988, the detection of an abnormal pterin compound in the urine of a French boy¹³ led to the discovery that the production of primapterin (from Primael, his first name), a 7-substituted isomer of biopterin, is because of the deficiency of pterin-4a-carbinolamine dehydratase (PCD), the first enzyme in the BH₄ salvage pathway.^{14,15} The first patients with HPA dependent on DHPR deficiency were two Japanese siblings, reported by Tada et al. in 1969,¹⁶ but enzymatically characterized in 1980.¹⁷ The original report of a definite diagnosis of DHPR deficiency was made by Kaufman et al. in 1975 in an American 14-month-old male infant who developed seizures and other neurological symptoms despite adequate treatment coherent with the previous diagnosis of PKU.¹⁸ A “central”

form of DHPR deficiency was recently reported following the observation of two Turkish boys presenting with suggestive neurological and cerebrospinal fluid (CSF) picture of pterin disorder, but without HPA.^{19,20} Investigation of their skin fibroblasts, however, provided evidence of an enzymatic block in the biosynthesis of BH₄ and impaired sepiapterin reductase (SR) activity, a finding supported by the detection of causative mutations in the *SPR* gene of both patients and family members²¹ and by high levels of sepiapterin in the CSF.²² The absence of HPA and the presence of normal urinary pterin pattern and of normal pterin metabolism in erythrocytes was explained by alternative pathways of BH₄ biosynthesis in peripheral and neuronal tissues. In the final two-step reaction, SR activity may be substituted by aldose reductase (AR), and/or carbonyl reductase (CR), and dihydrofolate reductase (DHFR) in the former, whereas in the latter only AR and CR are present (see Fig. 2).

These five forms of BH₄ deficiency are all autosomal recessively inherited, in contrast to an autosomal dominant form of GTPCH deficiency leading to Dopa-responsive dystonia, and originally known as Segawa disease or hereditary progressive dystonia with marked diurnal fluctuation.^{23,24} Diagnosis of SR deficiency and heterozygous GTPCH deficiency may be disregarded for years, as patients are not hyperphenylalaninemic and escape the screening procedures for PKU, needing specific diagnostic work-out.²⁵

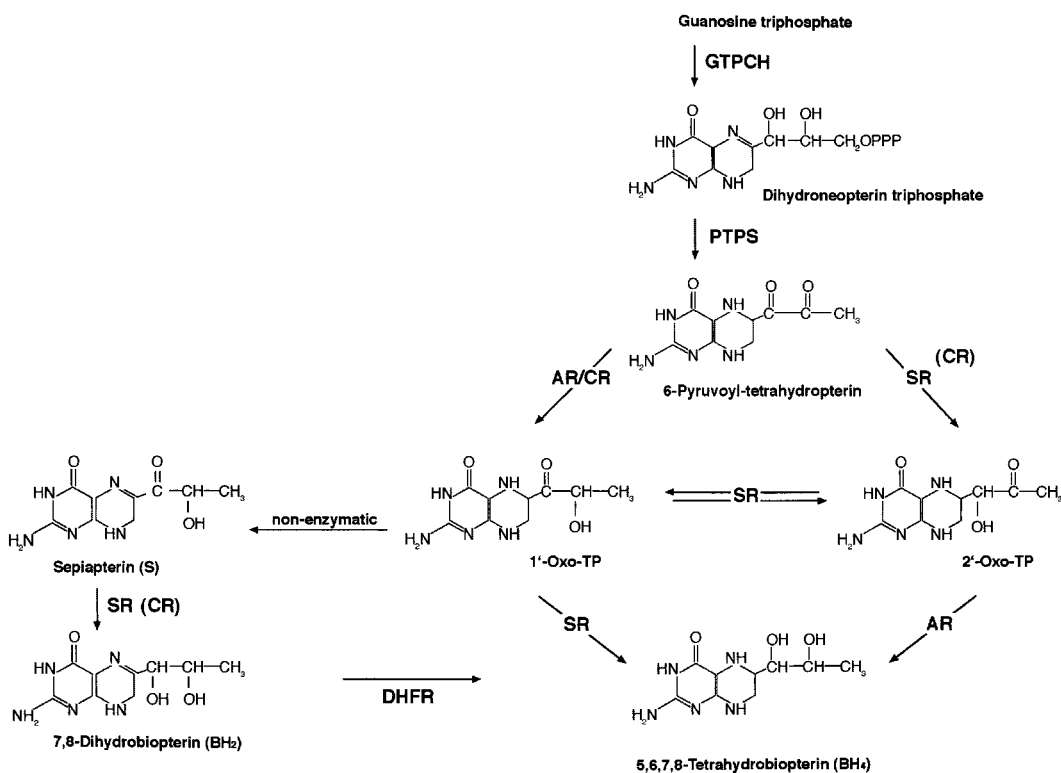

Figure 2. Biosynthesis of BH₄ and possible salvage pathways in sepiapterin reductase deficiency (courtesy of Prof. Dr. N. Blau, Zürich, CH). AR, aldose reductase; CR, carbonyl reductase; DHFR, dihydrofolate reductase; DHPR, dihydropteridine reductase; GTPCH, guanosine triphosphate cyclohydrolase I; PCD, carbinolamine dehydratase; PTPS, 6-pyruvoyl-tetrahydropterin synthase; SR, sepiapterin reductase; 1'-oxo-TP, 6-(1'-oxo-2'-hydroxypropyl)-tetrahydropterin; 2'-oxo-TP, 6-(1'-hydroxy-2'-oxopropyl)-tetrahydropterin.

3. REACTION MECHANISMS AND STRUCTURE OF DHPR

The hydroxylating system for aromatic amino acids has been thoroughly investigated, showing common features in the coupled reaction of the three hydroxylases (see Fig. 3). Molecular oxygen is transferred to the corresponding amino acid, BH_4 is oxidized, and the enzymes are reductively activated in stoichiometric amounts.⁷ PCD and DHPR are the enzymes involved in the regeneration of BH_4 , through subsequent dehydration and reduction of BH_4 -4a-carbinolamine, the oxidation product of BH_4 . The first step is catalyzed by the enzyme PCD with the formation of quinonoid dihydrobiopterin (q-BH₂), a reaction that may also occur non-enzymatically at a rate not sufficient to keep BH_4 in the reduced state.²⁶ In the case of PCD deficiency, BH_4 -4a-carbinolamine rearranges to a seven-substituted compound, the primapterin, which provides inhibitory activity on PAH and is excreted in the urine.²⁷ The conversion of q-BH₂ into BH_4 is finally catalyzed by DHPR in an NADH-dependent reaction, involving direct hydride transfer from the reduced nicotinamide ring to BH₂.²⁸

Human DHPR is a dimer composed by two identical subunits carrying two bound NADH molecules per dimer,⁷ with the properties reported in Table I.²⁹ Studies by immunoprecipitation and electrophoresis and comparison of antigen determinants demonstrated that enzyme proteins from different sources are identical and derived from the same structural gene.³⁰ X-ray crystallographic analysis of the DHPR–NADH binary complexes showed that DHPR is an α/β protein, composed by a central twisted β -sheet flanked on both sides by a layer of α -helices. Seven parallel and one anti-parallel strands at one edge lead to the C-terminus of the protein. The homodimer is formed by the hydrophobic interaction of a pair of helices from each subunit, with two active sites 30' Å apart.^{3,7} The topology of backbone folding and active sites are not fully defined, but they differ from DHFR, another pterin reductase possibly involved in BH_4 salvage from BH_2 .^{30,31}

DHPR is widely distributed in animal tissues, including tissues devoid of aromatic amino acid hydroxylating activity. This occurrence suggests an involvement in other processes, such as the reported ancillary role with DHFR in maintaining folate in the tetrahydro form in brain.³²

Regeneration of BH_4 after its oxidation by the hydroxylating system is essential. Cofactor *de novo* biosynthesis is not sufficient for controlling the homeostasis of aromatic amino acids and brain

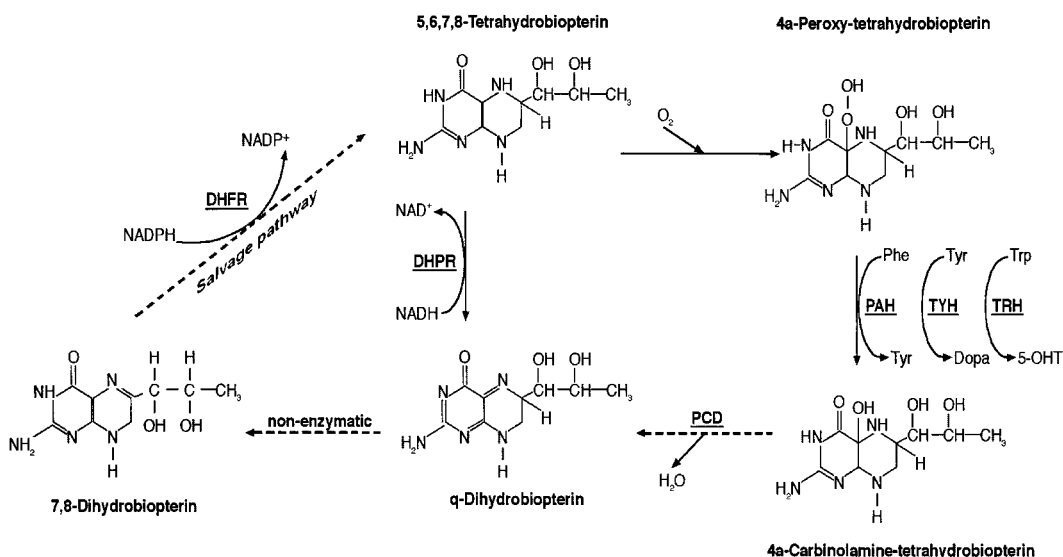

Figure 3. Aromatic amino acid hydroxylation system; dotted lines depict salvage pathways of BH_4 in dihydropteridine reductase deficiency (courtesy of Prof. Dr. N. Blau, Zürich, CH). DHFR, dihydrofolate reductase; DHPR, dihydropteridine reductase; PAH, phenylalanine hydroxylase; PCD, carbinolamine dehydratase; TRH, tryptophan hydroxylase; TYR, tyrosine hydroxylase.

Table I. Properties of Human Dihydropteridine Reductase (DHPR)²⁹

Molecular weight	
Sedimentation equilibrium	50,000
Gel filtration	47,500
Gradient gel electrophoresis	54,000
Subunit	26,000
Cross-linked dimer	58,000
Isoelectric point	7.0 ± 1.0
K _m (NADH 37°C, pH7.2)	29 μM
K _m (NADPH 37°C, pH7.2)	770 μM
K _m tetrahydrobiopterin	17 μM

neurotransmitters, as dramatically shown by the development of BH₄ deficiency in inherited DHPR deficiency. In this condition, however, some BH₄ recycling does occur,³³ either from q-BH₂ via methylene tetrahydrofolate reductase,³⁴ or from 7,8-dihydrobiopterin rearranged from the unstable q-BH₂ via DHFR (see Fig. 3).³⁵ The possible role in BH₄ salvage of a NADPH-dependent DHPR³⁶ has still to be evaluated. Because of the interferences between the activities of pterin and folate reductases, folate depletion in central nervous system is characteristically associated with DHPR deficiency, unlike other forms of BH₄ deficiency.

4. QDPR, THE GENE ENCODING DHPR

A cDNA clone for DHPR was isolated in 1987;^{37,38} it spanned the complete coding region and presented the nucleotide sequence and predicted amino acid sequence of the protein. Subsequently, the analysis of RFLPs has been used for prenatal diagnosis (PD) of DHPR deficiency.³⁹ The definite localization of the *QDPR* gene has been reported on chromosome 4p15.3 by in situ hybridization studies.⁴⁰ The DHPR cDNA is 1.2 kb long, contains an open reading frame of 732 bp³⁸ and encodes for a protein of 244 amino acids. The molecular weight of 25.744 predicted from the cDNA sequence was similar to the values reported for human liver^{29,30} and platelet^{41,42} DHPR.

The recent definition of the intron/exon gene structure⁴³ has enabled to search not only for coding mutations, accessible through cDNA, but also for mutations that affect intron/exon boundaries and result in RNA-splicing defects. The *QDPR* gene comprises 7 exons ranging 83–562 bp and the corresponding introns are flanked by canonic splice junctions. The promoter region has not been studied so far (see Fig. 4). The predicted amino acid sequence differs from that of the two other

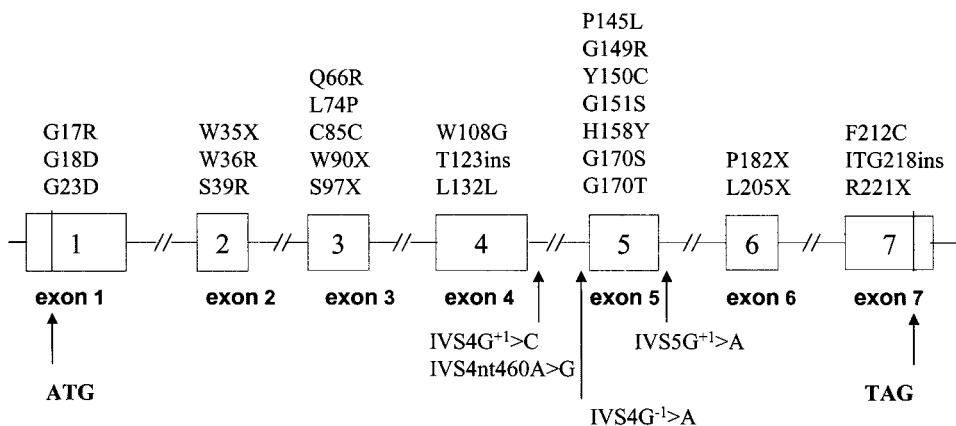
**Figure 4.** Genomic structure of *QDPR* gene and location of mutations included in BIOMDB.²

enzymes, which act on substituted pterin substrates and utilize a pyridine nucleotide factor, i.e., DHFR and methylene tetrahydrofolate reductase. Marginal similarities in the sequences of DHPR and DHFR occur in regions known to contain the binding sites for methotrexate and the pyridine nucleotide cofactors, suggesting vestigial homologies.^{34,44}

5. DHPR DEFICIENCY

A. Clinical and Biochemical Phenotype

The clinical presentation and course of typical, untreated cases of DHPR deficiency are quite similar to those seen in the other forms of BH₄ deficiency, with the exception of PCD deficiency, which is a benign and transient form of HPA not followed by neurological involvement³, and of SR deficiency.²¹ Whereas HPA is present since the neonatal period, the median age at the onset of clinical presentation is between 4 and 6 months. Abnormal signs and symptoms (low birthweight, microcephaly, tremors, hypotonia, poor suckling), however, may be present since birth, suggesting that *in utero* damage may have occurred. Within a few months, patients develop a typical neurological picture, firstly signaled by disturbances of muscular tone and posture (truncal hypotonia with limb hypertonia), tremors, drowsiness, irritability, and followed by hypokinesia, swallowing difficulties, hypersalivation, abnormal movements, oculogiric crises, “grand mal” or mioclonic convulsions, and recurrent episodes of hyperthermia without infection.^{45–48} These symptoms are because of the combined amine deficiency (Table II), fluctuate diurnally in their intensity, and can be completely reversed by treatment. With time, untreated patients develop progressive microcephaly associated with electroencephalogram paroxysmal activity and brain atrophy on computerized tomography or magnetic resonance scan. Derangement of folate metabolism, in addition, may be responsible in such cases for a brain picture shared with patients suffering from congenital folate malabsorption, characterized by perivascular calcifications and extensive neuronal loss in basal ganglia, central cortex, and white matter.^{49–53} Death generally occurs in infancy or childhood, with a likely misdiagnosis of encephalitis. Clinical heterogeneity is less common in DHPR deficiency as compared to other forms of BH₄ deficiency. Most patients, indeed, have a nearly complete deficiency of enzyme activity, thus resulting in a typical clinical picture. Actually, only 2 out of 137 patients listed in the BIODDEF database were considered affected by an “atypical” or “mild” form, with 4–10% residual enzyme activity in cultured fibroblasts.^{1,54} At the enzyme level, molecular heterogeneity was recognized to encompass cross reacting material (CRM)– and CRM+ forms, which can be further characterized by anti-idiotypic and anti-DHPR monoclonal antibodies.^{44,55} CRM+ patients have more severe HPA, and are less responsive to treatment, possibly because the mutated protein enzyme binds BH₄ making it unavailable.^{56,57}

Evaluation of the biochemical phenotype includes the analysis of Phe, biogenic amines, and folate metabolism. Data collected in patients at diagnosis are listed in Table III. A clear-cut definition of this phenotype, however, is hampered by the wide and overlapping range of values recorded, because of differences in procedures employed, patient age, and dietary regimen. We have tentatively

Table II. Symptoms Related to Specific Biogenic Amine Deficiency

<i>Dopamine</i>	<i>Serotonin</i>	<i>Noradrenaline</i>
Immobility	Depression	Axial hypotonia
Parkinsonism	Altered thermogenesis	Cerebellar symptoms
Sleepiness	Insomnia	Ptosis
Dystonia		
Eye rolling		
Hypersalivation		
Swallowing difficulties		

Table III. Biochemical Data at Diagnosis in Patients Affected by DHPR Deficiency^{1,46}

	DHPR deficiency	Controls (1 month- 2 years)
Plasma phenylalanine ($\mu\text{mol/l}$)		
at screening	120-3200 (n=71)	<120
at diagnosis	60-2600 (n=60)	<120
Phenylalanine tolerance (mg/Kg/day)	300-700	>1000
Urine (mmol/mol creatinine)		
neopterin	0.27-25.30 (n=75)	0.3-0.4
biopterin	3.40-29.85 (n=74)	0.5-3.0
% biopterin	24-92 (n=71)	44-77
CSF(nmol/l)		
neopterin	10.40-68.80 (n=42)	9-40
biopterin	34.20-117 (n=49)	10-50
% biopterin	45-88 (n=43)	32-87
HVA	16-198 (n=44)	100-900
5-HIAA	3-72 (n=50)	120-500
5-MTHF	0-100 (n=34)	63-182
Enzyme activity (erythrocytes, $\mu\text{U/g Hb}$)	0-0.5 (n=82)	2-5
BH₄ loading test (7.5 mg/Kg b.w.)	(n=17)	(n=10)
positive	9	0
negative	8	0
BH₄ loading test (20 mg/Kg b.w.)	(n=43)	(n=12)
positive	40	0
negative	3	12

n, Number of patients; CSF, cerebrospinal fluid; HVA, homovanillic acid; 5-HIAA, 5-hydroxyindole acetic acid; 5-MTHF, 5-methyltetrahydrofolic acid.

separated severe, intermediate, and mild phenotypes, according to the need for complete, partial, or none treatment, respectively. This allocation enabled also to draw some genotype–phenotype correlations in a subset of completely characterized patients.⁵⁸

B. Neonatal Screening for HPA and Selective Screening for BH₄ Deficiency

DHPR deficiency causes a severe disease, generally asymptomatic in the neonatal period, but treatable if early diagnosed, so fulfilling the main criteria for the neonatal screening. Moreover, it can be detected, though not identified, through the neonatal screening for PKU together with other forms

of BH₄ deficiency, so overcoming the objection of its rarity. Several tests for this selective screening were introduced in the last two decades to be applied to every newborn with even slight but persistent HPA.^{46,59,60} Only developed countries, however, have screening programs for PKU, and only few centers practice the selective screening for BH₄ deficiency. As a consequence, even today the majority of DHPK deficient patients receive a clinically oriented, late diagnosis, which heavily worsens their prognosis (see Fig. 5). A diagnostic algorithm for the selective screening of BH₄ deficiency among neonatal HPAs (see Fig. 6) was implemented in our department since the 1980s.^{59,61} In presence of elevated plasma Phe with concurrent normal or low plasma Tyr, two simple procedures can be accomplished for both the screening and diagnosis: the challenge to the administration of exogenous cofactor and the measurement of enzyme activity. Noteworthy, this selective screening has to be systematically done whatever the value of plasma Phe in the neonatal period, as even mild or borderline Phe elevations are seldom encountered and possibly confused with benign forms of PKU.

1. BH₄ Loading Tests

Different methods have been proposed to discriminate between patients with PAH or BH₄ deficiency, with intact or missing cofactor, according to the differential lowering of plasma Phe levels and increasing of plasma Tyr levels in response to BH₄ administration. Intravenous cofactor loading was firstly and successfully attempted by Danks et al.^{62,63} at the dose of 2 mg/kg b.w. in the mid-1970s. Increased purity and availability of synthetic cofactor allowed the introduction of an oral test,^{64,65} which was standardized at the dose of 7.5 mg/kg b.w.⁶⁶ However, it was soon ascertained that this procedure could miss the diagnosis of some DHPK deficient patients who failed to respond to this test.^{11,60,67} Non-responders were identified among patients sharing high plasma Phe levels or belonging to the CRM+ type.^{56,57,68} This limitation could be overcome by increasing to 20 mg/kg b.w. the dose of administered cofactor,^{67,69} though at least two patients have been reported who still failed to respond to this higher dose.^{67,70} All these different loading tests have to be applied to patients

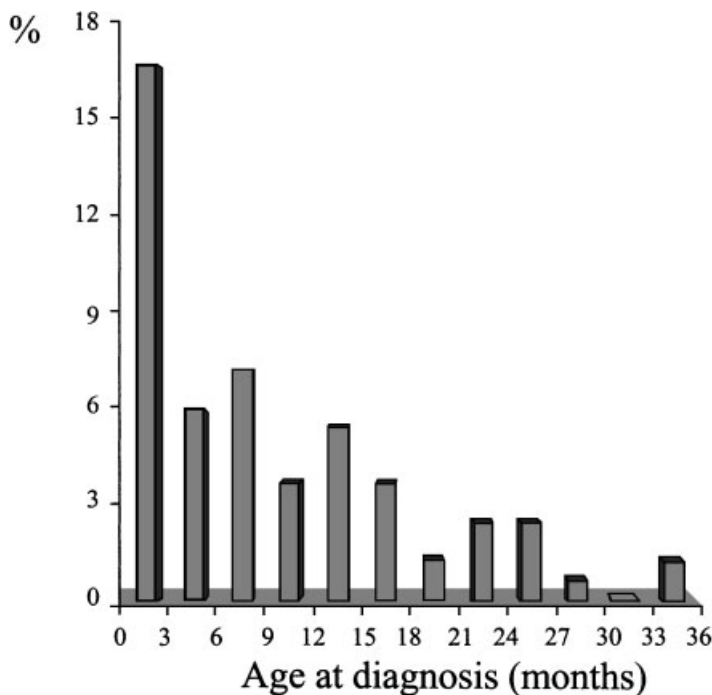

Figure 5. Age at diagnosis of patients affected by DHPK deficiency included in the patient BIDEF database.¹

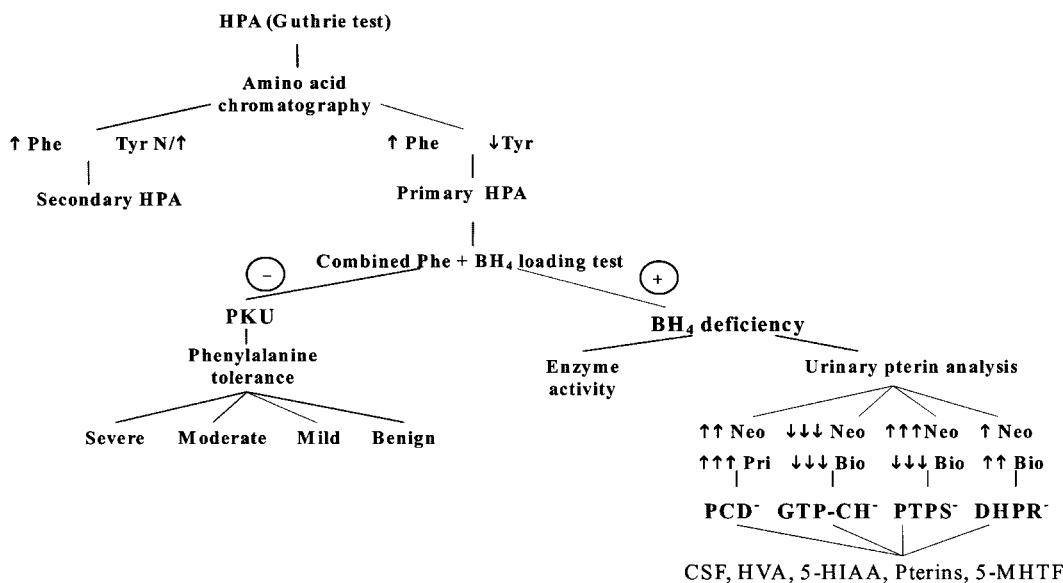

Figure 6. Diagnostic algorithm for neonatal hyperphenylalaninemia. HPA, hyperphenylalaninemia; Phe, phenylalanine; Tyr, tyrosine; Neo, neopterin; Bio, biopterin; Pri, primapterin; GTPCH⁻, guanosine triphosphate cyclohydrolase I deficiency; PTPS⁻, 6-pyruvoyl tetrahydropterin synthase deficiency; PCD⁻, carbinolamine dehydratase; DHPR⁻, dihydropteridine reductase deficiency; PKU, phenylketonuria; CSF, cerebrospinal fluid; HVA, homovanillic acid; 5-HIAA, 5-hydroxyindole acetic acid; 5-MHTF, 5-methyltetrahydrofolic acid.

while on spontaneous HPA, possibly exceeding plasma Phe levels of 400 $\mu\text{mol/L}$.³ A new diagnostic procedure was recently developed, based on the observation that high plasma Phe levels could exceed the impaired catalytic activity of BH₄ in DHPR deficiency.³³ A proper molar ratio between Phe and BH₄ was obtained by administering standard doses of both to patients retrieved to normal Phe plasma levels by dietary restriction. This combined loading test enables not only to identify BH₄ deficiency among primary HPAs, but also to discriminate between cofactor synthesis or regeneration defects (see Fig. 7). Actually, the former do fully respond by normalizing their Phe plasma levels within 4 hr, whereas DHPR deficient patients show an unequivocal response only 8 hr after BH₄ administration.⁷¹⁻⁷³ In its simplest form, this test can be interpreted by using four blood spots from a Guthrie card.

2. Enzyme Activity

Only 3–5 μL of peripheral blood obtained from Guthrie card spots are required for the measurement of DHPR activity in erythrocytes with the method of Arai et al.⁷⁴ The test is the most easy and rapid way to confirm or not the disease. It is based on the spectrophotometrical monitoring of the formation of ferrocytochrome-c in a coupled reaction, as represented in Figure 8. The enzyme in dried blood spots is stable enough for the sample to be mailed to a central laboratory, where the assay can be automated.⁷⁵ DHPR activity has been also detected in other cells, including leukocytes,⁷⁶ lymphocytes,⁷⁷ platelets,^{41,42} cultured fibroblasts,¹⁸ and amniocytes,⁷⁸ with more laborious and time-consuming methods. As expected, heterozygotes display about half normal enzyme activity, with only few exceptions, which display a much lower value and are possibly because of dominant negative mutations or to negative allelic complementation.^{79,80}

3. Urinary Pteridine Profile

Ultimate diagnosis has to be accomplished by more complex studies. Oxidized and reduced pterin analysis can be performed in urine, blood, and CSF by different methods.^{11,46,81-83} Random urine

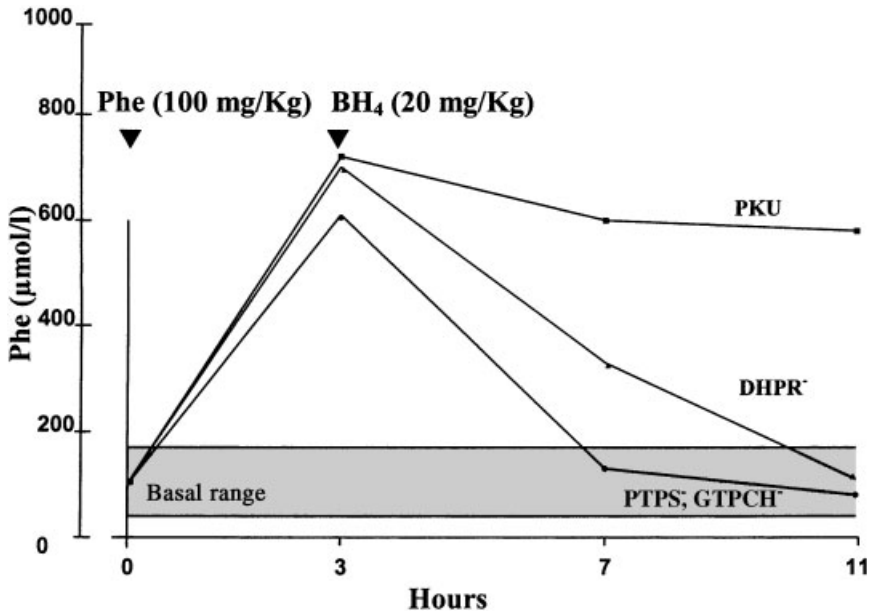

Figure 7. Differential response to the combined phenylalanine and BH₄ loading test in primary HPAs. BH₄, tetrahydrobiopterin; DHPR⁻, dihydropteridine reductase deficiency; GTPCH⁻, guanosine triphosphate cyclohydrolase I deficiency; Phe, phenylalanine; PKU, phenylketonuria; PTPS⁻, 6-pyruvoyl-tetrahydropterin synthase deficiency.

specimens dried on filter paper can also be used, with the advantage that they can be mailed unfrozen.^{84–86} Samples are oxidized to convert BH₄, q-BH₂, and BH₂ to total biopterin, and dihydroneopterin to neopterin. Separation by HPLC then results in pterin profiles characteristic for each form of HPA (Fig. 9). In DHPR deficient patients, biopterin is generally elevated, with a percentage greater than 80%, mainly because of the accumulation of 7,8-BH₂ tautomerized from q-BH₂, whereas neopterin is normal or slightly elevated. The pterin profile, however, is not unambiguously altered as compared to other forms of HPA. Actually, pterin synthesis is activated either by the lack of BH₄ feedback inhibition of GTP or by high plasma Phe levels.^{87,88} Moreover, pterin levels are higher in newborns than in infants or children.^{81,89,90} As a consequence, if relying only on the appearance of pterin profile, the diagnosis of DHPR deficiency may be missed in newborns on Phe-restricted diet or a misdiagnosis may be done in PKU patients, unless oxidized/reduced forms of biopterin are measured (by differential oxidation or electrochemical detection).^{46,83}

4. Neurotransmitter and Folate Measurement

Measurement of CSF neurotransmitters is useful for treatment monitoring more than for diagnosis of DHPR deficiency. The main catabolites of dopamine and serotonin are homovanillic acid (HVA) and 5-hydroxyindole acetic acid (5-HIAA), respectively. As their CSF concentration definitely reflects the neurotransmitter turnover, their measurement is preferred for technical reasons.^{91,92} Typical forms of BH₄ deficiency share similar low levels of neurotransmitter catabolites, irrespectively of the enzyme

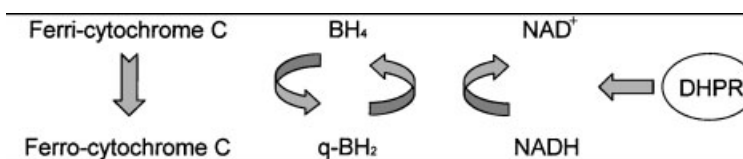

Figure 8. Assay of DHPR activity in erythrocytes (from Arai et al.⁷⁴ modified).

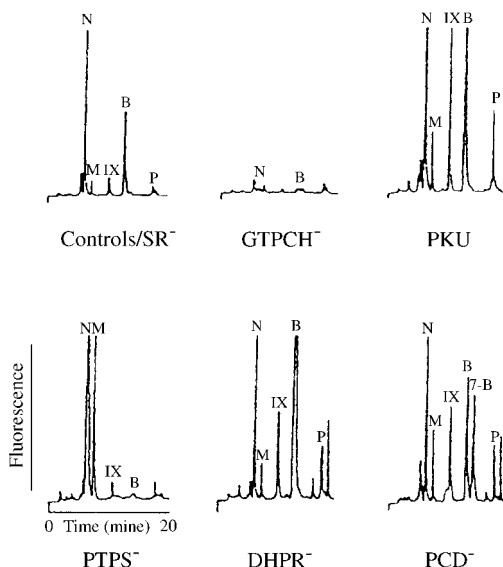

Figure 9. HPLC profiles of urinary pterins (oxidized) from healthy controls and patients with different forms of HPA (courtesy of Prof. Dr. N. Blau, Zürich, CH). N, neopterin; M, monapterin; IX, isoxanthopterin; B, biopterin; 7-B, primapterin; P, pterin; GTPCH⁻, guanosine triphosphate cyclohydrolase I deficiency; PKU, phenylketonuria; PTPS⁻, 6-pyruvoyl-tetrahydropterin synthase deficiency; DHPR⁻, dihydropteridine reductase deficiency; PCD⁻, carbinolamine dehydratase deficiency; SR⁻, sepiapterin reductase deficiency.

defect, with a more pronounced reduction of 5-HIAA.¹ The use of age-related ranges, however, is of capital importance, as neurotransmitter concentrations decrease rapidly in the first months after birth and slowly thereafter.^{92,93} The CSF concentration of 5-methyltetrahydrofolic acid shows a similar trend, and can be concurrently measured by HPLC with coulometric electrochemical detection for differential diagnosis and treatment.⁹⁴

C. Molecular Diagnosis

So far 32 mutations in the *QDPR* gene have been identified in 130 DHPR deficient patients (see Fig. 4).^{54,95–101} They include 30 causal mutations and two polymorphic variants (L132 G → A; C85 C → T). Twenty-six causal mutations are uniformly scattered throughout the coding region. Eighteen are missense, three non-sense, and three deletions, resulting in a premature termination of the peptide chain, two are insertions of one and three amino acids. Three mutations have been identified in the donor splice sites of introns 4 and 5, respectively.¹⁰¹ A fourth intronic mutation observed in intron 4 generates a sequence similar to a donor splice site, activates an upstream cryptic acceptor site, and produces an abnormal extra exon.¹⁰⁰ The inserted sequence contains a termination codon and thus most probably affects mRNA stability.

The BIOMDB¹ and BIODEF² databases were used to compare clinical and molecular data from patients carrying the same genotype. A genotype–phenotype correlation was observed,⁴³ notwithstanding the problem posed by molecular heterogeneity and the absence of standard diagnosis and treatment procedures. To obtain a clear definition of phenotypes, we used an approach based on the treatment required by our patients. Severe, intermediate, and mild phenotypes were distinguished on the basis of different treatment that was necessary: complete therapy with neurotransmitter precursors and BH₄ or diet, BH₄ monotherapy, and no therapy, respectively. To compare different mutations, we considered their effect on the protein, as shown by *in vitro* expression studies of the mutant enzyme, or expected by the mutation type. A correspondence between the type of mutation, enzyme residual activity, and the clinical phenotype was apparent, as mutations which drastically

subvert enzyme activity are associated with a severe phenotype, whereas a milder disease is peculiar in patients who carry mutants associated with apparent residual activity.^{43,101} G23D and H158Y were always associated with a severe phenotype in homozygotes. G23D affects the binding site for NADH, whereas H158Y most probably disrupts the overall protein structure, as inferred from the *in vitro* expression of mutant enzymes.⁹⁶ Both mutations, in fact, severely affect the enzyme activity. Similarly, the non-sense mutation R221X, which is assumed to encode for a truncated protein, was associated with a severe phenotype in the two patients, which carried it in homozygosity. Another patient with a severe phenotype carries the mutation R221X in compound heterozygosity with a missense mutation, G17V, within the highly conserved motif involved in NADH binding. Mutation L14P has been described in homozygosity in a patient with a severe phenotype. This amino acid substitution at position 14 within the $\beta\alpha\beta$ structure required for NADH binding probably predisposes the protein to rapid degradation, as no protein was detectable by immunoprecipitation.¹⁰¹ Three mutations affecting the donor site of introns 4 and 5 (IVS4G – 1A, IVS4G + 1C, and IVS5G + 1A) were found in association with a severe phenotype in three homozygous patients. All these mutations disrupt the maturation of the DHPR transcript such that little full-length mRNA can be detected by RT-PCR.¹⁰¹ The IVS5G + 1A mutation was also identified in compound heterozygosity with a three amino acid insertion in exon 7 in a patient who does not display a severe phenotype. The inframe insertion may not grossly alter its mutant enzyme activity: its expression in an *in vitro* system may provide the only way in which the effect of this mutation can be determined. The mild Y150C mutation in compound heterozygosity with the severe G23D mutation resulted in an intermediate phenotype. The mutant enzyme for Y150C was expressed in an *E. coli* system. Its kinetic parameters, as evaluated with both natural quinonoid 6 (R)-7,8(6H)-dihydrobiopterin and non-natural quinonoid 6-methyl (R,S)-7,8-dihydropterin and NADH, and compared to those of the G23D mutant showed that it was not as effective as the wild-type enzyme, but better than the G23D mutant with respect to both pterin substrates and NADH. This patient's intermediate phenotype is thus most probably because of the Y150C mutation. Two patients homozygous for G151S and F212C mutations were considered to have a mild phenotype as they do not require any treatment.⁵⁴ They show little red blood cell enzyme activity, but have substantial residual enzyme activity in fibroblasts, ~4 and ~10%, respectively (evaluation of DHPR activity is more precise on fibroblasts). Only the G151S mutant had been expressed *in vitro*,¹⁰² retaining its activity better than both G23D and Y150C mutants. The conservative substitution (Gly to Ser) involved in this mutation may explain the substantial activity and mild disease in this patient.

In conclusion, most mutations have devastating effects, but two are associated with a mild outcome and one with an intermediate phenotype. It is noteworthy that all the mutant enzymes characterized so far by *in vitro* expression studies retain a certain activity, in keeping with the hypothesis that the housekeeping DHPR may be necessary for sustaining life.¹⁰²

The observed genotype–phenotype correlation supports the implementation of neonatal molecular diagnosis programs. The possibility of predicting some residual enzyme activity by DNA analysis performed already in the newborn period may allow the prompt application of a treatment adjusted to the degree of enzyme deficiency. This may improve management and prognosis. The advent of molecular techniques, specifically those PCR-based, has resulted in unparalleled advances in diagnostic sensitivity. Because of its ability to amplify small quantities of DNA, PCR has proven particularly successful for use with Guthrie card bloodspots, even in retrospective studies. The advent of chip technology coupled to PCR will allow a gene to be completely scanned in a single technical test,^{103–105} so resulting theoretically the solution less expensive for neonatal molecular diagnosis.

D. Treatment and Prognosis

The severity of DHPR deficiency in man is closely related to the impairment of aromatic amino acid hydroxylation and folate homeostasis, resulting in HPA, biogenic amine deficiency, and

tetrahydrofolate depletion. A combination of therapies addressed to the correction of these metabolic derangements has to be promptly applied after diagnosis, to avoid irreversible brain damage and worsening of prognosis (Table IV).

1. Treatment of HPA

The control of HPA can be achieved either by a Phe-restricted diet or by administration of synthetic BH₄. Newborns and infants affected by DHPR deficiency exhibit a dietary Phe tolerance higher than PKU patients, ranging 300–700 mg/kg/per day.¹⁰⁶ Though prospective studies are lacking, personal observations suggest that Phe tolerance increases consistently with patient age, even approaching normal levels at puberty. Phe restriction is calculated according to the lines employed in PKU, and combined with Tyr supplementation. Plasma Phe concentration, however, has to be maintained lower than in PKU, as high Phe levels alter neurotransmitter metabolism, possibly by interfering with precursor transfer across the neuronal cell membranes.^{107,108}

The administration of exogenous BH₄ is the easiest way to control HPA in BH₄ synthesis defects, as single and small daily doses (2–5 mg/kg) are sufficient to maintain plasma Phe within normal levels.^{46,59,109} The use of cofactor in DHPR deficiency, vice versa is still controversial, as it has been accepted for a long time that the absence of DHPR activity will restrict BH₄ to function only stoichiometrically, so requiring very high doses (70–120 mg/kg/day) to simply keep pace with the Phe hydroxylation reaction.^{110–112} A dramatic lowering of plasma Phe was readily obtained, however, by an intravenous dose of 2 mg/kg BH₄,^{62,63} and a similar response was obtained in DHPR deficient patients given an oral loading with 5–20 mg of this cofactor.^{11,60,67,69} More recently, by comparing the kinetics of plasma Phe after BH₄ loading in PAH and DHPR deficient patients, we demonstrated that the molar equivalent of Phe hydroxylated per mole of BH₄ ranged in the latter from 6 to 10, against the theoretical 1.^{33,71} Different explanation for this partial cofactor recycling may be offered, including DHPR residual activity and alternative salvage pathways. Clinical trials of BH₄ therapy in patients were consistent with the above findings, as a daily dosage of 8–20 mg/kg/day, divided into three or four administrations, allowed patients to stay on a Phe free diet.^{33,113} Two different forms of BH₄ are produced (6R,S and 6R) and provided by Schirks Laboratories (Jona, CH) and by Suntory Ltd. (Tokyo, Japan). Only the 6R form is the biologically active isomer, thus the dosage of the isomeric mixtures of 6R,S must be higher. The cofactor therapy is administered throughout life and is very expensive in DHPR deficiency, because of larger doses requested according to the increasing patient weight. Despite substantial amounts of exogenous BH₄ which can be found in CSF after oral administration,^{114,115} in most patients BH₄ monotherapy is ineffective in restoring sufficient dopamine and serotonin levels, thus neurotransmitter replacement is necessary.^{33,113}

2. Substitutive Neurotransmitter Therapy

First attempts at compensating neurotransmitter deficiency were made successfully in 1975.¹¹⁶ The hydroxylated precursors L-Dopa and 5-hydroxy-tryptophan (5-OH-Trp) were administered in combination with an inhibitor of peripheral amino acid decarboxylases, such as carbidopa or benzerazide, to reduce the L-Dopa requirement. This treatment must be accurately handled, because the neuroreceptors of patients are very sensitive. Low doses of L-Dopa stimulate presynaptic receptors and decrease decarboxylase activity, whereas high doses inhibit post-synaptic receptors,⁴⁵ with the appearance of symptoms (involuntary movements, dyskinesia, irritability, insomnia, opisthotone) difficult to distinguish from those of undertreatment. Overdose symptoms related to the use of 5-OH-Trp are more specific, and mainly represented by diarrhea, vomiting, midriasis, and tachycardia.^{59,117} Neurotransmitter replacement should always be started at low doses, divided into three daily administrations and progressively increased under careful monitoring. This can be implemented either clinically, by evaluating the minimal dose effective in relieving specific symptoms, or

Table IV. Different Options to be Evaluated for the Treatment of Patients Suffering From DHPR Deficiency

Metabolic derangement	Therapy	Number of administrations/day	
Hyperphenylalaninemia	Low-Phe diet (according to the individual tolerance) or Tetrahydrobiopterin 8-20 mg/kg/day	3-4	
Neurotransmitter deficiency	Hydroxylated precursors and/or L-Dopa (+ 10% carbidopa) 5-OH-Tryptophan Monoamine oxidase inhibitors Catechol-O-methyl transferase inhibitors	Tetrahydrobiopterin 20 mg/kg/day initially: 1-2 mg/kg/day <2 years: 5 mg/kg/day >2 years: 8-10 mg/kg/day initially: 1-2 mg/kg/day <2 years: 5 mg/kg/day >2 years: 5-8 mg/kg/day L-deprenyl: 0.3 mg/kg/day	3-4 3 3 3 3 3 1
Tetrahydrofolate depletion	Folinic acid 10-20 mg/kg/day	2-3	
	Entacapone 15 mg/kg/day	1	

eventually:
 -fractionation into 6-8
 administrations
 -addition of dopamine
 agonists

biochemically, by periodically measuring the CSF concentration of HVA and 5-HIAA. Actually, good clinical results may be achieved in these patients at levels of neurotransmitter catabolites even lower than those of age-matched controls.^{118,119} To avoid repeated lumbar punctures, the measurement of serum prolactin may be a suitable approach for their follow-up. Untreated patients invariably display marked hyperprolactinemia, which can be normalized by L-Dopa administration. Since dopamine is the physiologic inhibitor of prolactin secretion, the serum concentration of prolactin appears inversely related to the CSF concentration of HVA.^{120–122} Unfortunately, higher doses of neurotransmitter precursors are progressively required with age, thus generating in patients diurnal symptoms fluctuations, overdose effects, or on–off phenomena.¹²³ Aliquoting of the daily dosage into six to eight administrations or concurrent treatment with Dopa agonists such as bromocryptine have been proposed with only partial success,^{59,124} whereas some result was obtained in similar cases with the concurrent administration of RL-Deprenyl (Selegiline, phenylisopropylmethylpropynylamine) a selective monoamine oxidase B inhibitor which allows a 10% reduction in the dosage of neurotransmitter precursors by curtailing their catabolism.^{113,125,126} Actually, substitutive therapy with L-Dopa represents the most critical aspect in the treatment of DHPR deficiency, as pharmacological disadvantages or adverse effects encompass both its short-term and long-term outcome. The former are mainly because of the short L-Dopa plasma half-life, consequent to its rapid absorption and metabolism through decarboxylation and methylation. Diurnal fluctuations of L-Dopa plasma concentration, and hence of brain dopamine, wane the clinical benefits, resulting in turn in dyskinesia at the onset, and in “wearing off” or “end-of-dose” pattern of motor activity at the end of each dose cycle. With time, patients may develop a complex syndrome including neuropsychiatric and gastrointestinal symptoms, possibly related to the accumulation of L-Dopa methyl-metabolites.¹²⁷ A recent strategy (already introduced in Parkinson’s disease) has centered on increasing the availability of intracellular L-Dopa and synaptic dopamine by curtailing the peripheral and central metabolism of L-Dopa to 3-*O*-methyl-dopa with the use of catechol-*O*-methyltransferase (COMT) inhibitors.¹²⁸ According to this line, we are treating DHPR and other forms of BH₄ deficiency with Entacapone (COMTAN, Novartis GmbH, Germany), a selective, reversible, nitrocatechol-type, COMT inhibitor. Entacapone can be administered together with L-Dopa at the dose of 15 mg/kg/day. It allows a 30% reduction of the dosage of L-Dopa and ensures a good control of choreal symptoms with only two or three daily L-Dopa administrations. Increased dopamine production is paralleled by plasma prolactin normalization and almost 60% reduction of methyl-dopa plasma concentrations.^{129,130} The full strategy of L-Dopa therapy with inhibitors of metabolic enzymes is represented in Figure 10.

3. Treatment of Folate Depletion

Chronic administration of folinic acid at the dose of 10–20 mg/kg/day is also mandatory in DHPR deficiency, as reported earlier by Smith et al.¹³¹ because of interferences between the activities of pterin and folate reductases. Obviously, antifolic drugs have to be avoided in such patients.

The best strategy in treatment must be thoroughly searched for in each patient by evaluating the differential response to different options, as shown by Spada et al.¹¹³

4. Prognosis

The clinical presentation of DHPR deficiency is more severe as compared to other severe forms of BH₄ deficiency and death unavoidably occurs within few years in untreated patients. On the contrary, the response to the treatment is more prompt and complete. Patients’ outcome can be very favorable, possibly because of preserved synthesis of reduced pterins and improving Phe tolerance. It is heavily conditioned, however, by the age at diagnosis and by the quality of treatment: delay in treating neonatal HPA, adverse effects to neurotransmitter replacement, and missed folinic acid administration heavily worsen the severity of prognosis.^{45,46,59}

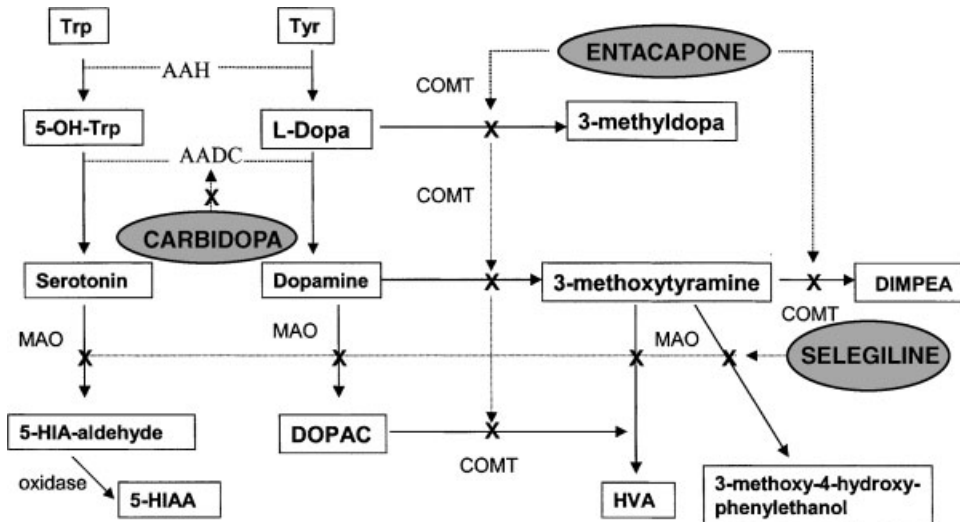

Figure 10. Inhibition of aromatic amino acid decarboxylase, catechol-*O*-methyl transferase and monoamine oxidase in L-Dopa therapy. AADC, aromatic amino acid decarboxylase; AAH, aromatic amino acid hydroxylase; COMT, catechol-*O*-methyl transferase; DIMPEA, 3,4-dimethoxyphenylethylamine; DOPAC, 3,4-dihydroxyphenylacetic acid; HVA, homovanillic acid; MAO, monoamine oxidase; Trp, tryptophan; Tyr, tyrosine; 5-HIA-aldehyde, 5-hydroxyindole aldehyde; 5-HIAA, 5-hydroxyindole acetic acid; 5-OH-Trp, 5-hydroxytryptophan.

E. Genetics

On the basis of inheritance, occurrence in both sexes, consanguinity and genotype, DHPR deficiency is an autosomal recessive trait.³ According to the literature, the disease is very rare, with a cumulative prevalence accounting for 0.3–0.6% among cases of primary HPA,¹³² and corresponding to an incidence of 1:30⁵ live births. Since its only early marker is the blood Phe elevation before clinical symptoms have been established, definite figures have become available only for countries that developed neonatal mass screening for PKU and selective screening for BH₄ deficiencies. Their worldwide distribution appears panethnic and pangeographic, resulting in higher prevalence among HPAs in countries where frequency of PKU is low, such as Japan, Taiwan, Saudi Arabia.^{1,46,133–135}

Reported cases of DHPR deficiency account for one third of all the forms of BH₄ deficiency, and two thirds of them are of Caucasian origin (see Fig. 1). Clustering of DHPR deficiency, supported by genotypic analysis, is scattered over the Mediterranean basin and the European Middle-East area,^{1,46,134,136} because of endogamy or genetic drift. DHPR deficiency seems slightly more homogeneous in the Mediterranean populations where a founder effect has been hypothesized for at least four mutations, G23D, H158Y, L14P, and R221X, which have been found in unrelated patients more than once.^{43,97–99}

F. Prenatal Diagnosis and Carrier Detection

PD is often requested by families at risk, because of the severity of the disease, difficulty of treatment, and disparity of outcome. The application to the fetus of diagnostic techniques already introduced after birth enabled to obtain antenatal information in pregnancies at risk for DHPR deficiency. Since DHPR activity is expressed early during the fetal life,¹³⁷ and amniotic pterins are the product of fetal synthesis and metabolism,^{138–140} a number of fetal sources are available for a reliable PD, including amniotic fluid, erythrocytes, amniocytes, and chorionic villi.^{141,142} In affected fetuses, the amniotic fluid pterin pattern is comparable to that found in urine of affected patients, with high

biopterin and normal or slightly elevated neopterin. Pterin measurement, however, is reliable for detecting the homozygous fetus for the defect, but not for discriminating between the heterozygous and normal fetus. It should also be noted that both normal and heterozygous fetus may share levels of increased primapterins relatively to 6-biopterin.¹⁴³ When PD relies on erythrocyte DHPR activity, it must be taken into account that fetal red blood cells show approximately 20% lower enzyme activity.¹³⁷

Recombinant DNA technologies possibly represent the most direct method and offer the advantage of a first-trimester diagnosis using chorionic villi. PD is feasible by using mutations and using informative intragenic polymorphisms. The inheritance of different alleles can be traced in families with an affected offspring to determine the mutant allele, even when the causal mutation has not been characterized.⁶¹ PD using mutations has the disadvantage that most families carry private mutations; thus time-consuming screening procedures have to be performed prior to pregnancy to characterize the specific mutation. Probably, the advent of rapid methods for mutation screening and scanning will facilitate molecular diagnosis of single patients. So far a single PD has been performed by the use of RFLPs,³⁹ and two by the specific mutation detection.^{144,145} In total, using biochemical or molecular tools, 12 PDs have been performed in families at risk for DHPR deficiency.⁶¹

Carrier status for BH₄ defects can be identified by evaluation of the enzyme activity or by mutation detection. The high price of these analyses and mutation heterogeneity do not make them available at a population level. The less expensive is probably the determination of enzyme activity, which can be done on Guthrie spots and has been used in the past to screen many samples from individuals.¹³⁶ Molecular carrier diagnosis is feasible in families with an affected sibling when the responsible mutation has been characterized.

Abbreviations

5-HIAA	5-Hydroxyindole acetic acid
5-OH-Trp	5-Hydroxy-tryptophan
AR	Aldose reductase
BH ₄	Tetrahydrobiopterin
COMT	Catechol- <i>O</i> -methyl transferase
CR	Carbonyl reductase
CRM	Cross reacting material
CSF	Cerebrospinal fluid
DHFR	Dihydrofolate reductase
DHPR	Dihydropteridine reductase
GTPCH	Guanosine triphosphate cyclohydrolase I
HPA	Hyperphenylalaninemia
HVA	Homovanillic acid
PAH	Phenylalanine-4-hydroxylase
PCD	Pterin-4a-carbinolamine dehydratase
PD	Prenatal diagnosis
Phe	Phenylalanine
PKU	Phenylketonuria
PTPS	6-Pyruvoyl-tetrahydropterin synthase
q-BH ₂	Quinonoid dihydrobiopterin
RFLP	Restriction fragment length polymorphism
SR	Sepiapterin reductase
Trp	Tryptophan
Tyr	Tyrosine

ACKNOWLEDGMENTS

The authors are grateful to Prof. Wilfred L.F. Armarego, Division of Molecular Bioscience, John Curtin School of Medical Research, the Australian National University, Canberra, Australia; to Prof. Nenad Blau, Division of Clinical Chemistry and Biochemistry, University Children's Hospital, Zürich, Switzerland; to Prof. Richard G.H. Cotton, Genomic Disorders Research Centre, St. Vincent's Hospital, Melbourne, Australia, for their long-lasting and invaluable collaboration, discussion, and suggestion throughout these studies.

REFERENCES

1. Blau N, Dhondt JL. BIODREF: International database of tetrahydrobiopterin deficiencies <http://www.bh4.org/biodef1.html>
2. Blau N, Thöny B, Dianzani I. BIOMDB: Database of mutations causing tetrahydrobiopterin deficiency <http://www.bh4.org/biomdb1.html>
3. Blau N, Thöny B, Cotton RGH, Hyland K. Disorders of tetrahydrobiopterin and related amines. In: Scriver CR, Beaudet AL, Sly WS, Valle D, editors. *The metabolic and molecular bases of inherited diseases*. New York: McGraw-Hill; 2001. pp 1725–1776.
4. Leeming RJ, Blair JA, Green A, Raine DN. Biopterin derivatives in normal and phenylketonuric patients after oral loads of L-phenylalanine, L-tyrosine, and L-tryptophan. *Arch Dis Child* 1976;51:771–777.
5. Tanaka K, Kaufman S, Milstien S. Tetrahydrobiopterin, the cofactor for aromatic amino acid hydroxylases, is synthesized by and regulates proliferation of erythroid cells. *Proc Natl Acad Sci* 1989;86:5864–5867.
6. Liang LP, Kaufman S. The regulation of dopamine release from striatum slices by tetrahydrobiopterin and L-arginine-derived nitric oxide. *Brain Res* 1998;800:181–186.
7. Thöny B, Auerbach G, Blau N. Tetrahydrobiopterin biosynthesis, regeneration, and functions. *Biochem J* 2000;347:1–16.
8. Smith I. Atypical phenylketonuria accompanied by a severe progressive neurological illness unresponsive to dietary treatment. *Arch Dis Child* 1974;49:245–248.
9. Bartholomè K. A new molecular defect in phenylketonuria. *Lancet* 1974;2:1580.
10. Niederwieser A, Blau N, Wang M, Joller P, Atares M, Cardesa-Garcia J. GTP-cyclohydrolase I deficiency, a new enzyme defect causing hyperphenylalaninemia with neopterin, biopterin, dopamine, and serotonin deficiencies and muscular hypotonia. *Eur J Pediatr* 1984;141:208–214.
11. Niederwieser A, Ponzone A, Curtius HC. Differential diagnosis of tetrahydrobiopterin deficiency. *J Inher Metab Dis* 1985;8(Suppl 1):34–38.
12. Niederwieser A, Leimbacher W, Curtius HC, Ponzone A, Rey F, Leupold D. Atypical phenylketonuria with “dihydrobiopterin synthetase” deficiency: Absence of phosphate eliminating enzyme activity demonstrated in liver. *Eur J Pediatr* 1985;144:13–16.
13. Dhondt JL, Guibaud P, Rolland MO, Dorche C, Andre S, Forzy G, Hayte IM. Neonatal hyperphenylalaninemia presumably caused by a new variant of biopterin synthetase deficiency. *Eur J Pediatr* 1988;147:153–157.
14. Curtius HC, Adler C, Rebrin I, Heizmann C, Ghisla S. 7-Substituted pterins: Formation during phenylalanine hydroxylation in the absence of dehydratase. *Biochem Biophys Res Commun* 1990;172:1060–1066.
15. Blaskovics M, Giudici TA. A new variant of biopterin deficiency. *N Engl J Med* 1988;319:1611–1612.
16. Tada K, Yoshida T, Mochizaka K, Konno T, Nakagawa H, Yokoyama Y, Tokada G, Arakawa T. Two siblings with hyperphenylalaninemia: Suggestion to a genetic variant of phenylketonuria. *Tohoku J Exp Med* 1969;100:249–253.
17. Tada K, Narisawa K, Arai N, Ogasawara Y, Ishizawa S. A sibling case of hyperphenylalaninemia due to a deficiency of dihydropteridine reductase: Biochemical and pathological findings. *Tohoku J Exp Med* 1980;132:123–131.
18. Kaufman S, Holtzman NA, Milstein S, Butler LJ, Krumholz A. Phenylketonuria due to a deficiency of dihydropteridine reductase. *N Engl J Med* 1975;293:785–790.
19. Blau N, Thöny B, Renneberg A, Arnold LA, Hyland K. Dihydropteridine reductase deficiency localized to the central nervous system. *J Inher Metab Dis* 1998;21:433–434.
20. Blau N, Thöny B, Renneberg A, Penzien JM, Hyland K, Hoffmann G. Variant of dihydropteridine reductase deficiency without hyperphenylalaninemia: Effect of oral phenylalanine loading. *J Inher Metab Dis* 1999;22:216–220.

21. Bonafé L, Thöny B, Penzien JM, Czaarnecki B, Blau N. Mutations in the sepiapterin reductase gene cause a novel tetrahydrobiopterin-dependent monoamine-neurotransmitter deficiency without hyperphenylalaninemia. *Am J Hum Genet* 2001;69:269–277.
22. Zorzi G, Redweik U, Trippe H, Peuzien JM, Thöny B, Blau N. Detection of sepiapterin in CSF of patients with sepiapterin reductase deficiency. *Mol Gen Metab* 2002;75:174–177.
23. Segawa M, Hosaka A, Miyagawa F, Nomura Y, Imai H. Hereditary progressive dystonia with marked diurnal fluctuation. *Adv Neurol* 1976;14:215–233.
24. Ichinose H, Ohye T, Takahashi E, Seki N, Hori T, Segawa M, Nomura Y, Endo K, Tanaka H, Tsuji S. Hereditary progressive dystonia with marked diurnal fluctuation caused by mutations in the *GTP* cyclohydrolase I gene. *Nat Genet* 1994;8:236–242.
25. Blau N, Bonafé L, Thöny B. Tetrahydrobiopterin deficiencies without hyperphenylalaninemia: Diagnosis and genetics of DOPA-responsive dystonia and sepiapterin reductase deficiency. *Mol Genet Metab* 2001;74:172–185.
26. Bailey SW, Boerth SR, Dillard SB, Ayling J. The mechanism of cofactor regeneration during phenylalanine hydroxylation. *Adv Exp Med Biol* 1993;338:47–54.
27. Davis MD, Kaufman S, Milstien S. Conversion of 6-substituted tetrahydropterins to 7-isomers via phenylalanine hydroxylase-generated intermediates. *Proc Natl Acad Sci* 1991;88:385–389.
28. Armarego WL, Randles D, Waring F. Dihydropteridine reductase (DHPR), its cofactors, and its mode of action. *Med Res Rev* 1984;4:267–321.
29. Firgaira FA, Cotton RG, Danks DM. Isolation and characterization of dihydropteridine reductase from human liver. *Biochem J* 1981;197:31–43.
30. Firgaira FA, Choo KH, Cotton RG, Danks DM. Molecular and immunological comparison of human dihydropteridine reductase in liver, cultured fibroblasts, and continuous lymphoid cells. *Biochem J* 1981;197:45–53.
31. Nichol CA, Smith GK, Duch DS. Biosynthesis and metabolism of tetrahydrobiopterin and molybdopterin. *Annu Rev Biochem* 1985;54:729–764.
32. Pollock RJ, Kaufman S. Dihydropteridine reductase may function in tetrahydrofolate metabolism. *J Neurochem* 1978;31:115–123.
33. Ponzzone A, Guardamagna O, Dianzani I, Ponzzone R, Ferrero GB, Spada M, Cotton RG. Catalytic activity of tetrahydrobiopterin in dihydropteridine reductase deficiency and indications for treatment. *Pediatr Res* 1993;33:125–128.
34. Matthews RG, Kaufman S. Characterization of the dihydropteridine reductase activity of pig liver methylenetetrahydrofolate reductase. *J Biol Chem* 1980;255:6014–6017.
35. Scriver CR, Kaufman S. Hyperphenylalaninemia: Phenylalanine hydroxylase deficiency. In: Scriver CR, Beaudet AL, Valle D, editors. *The metabolic and molecular bases of inherited disease*. New York: McGraw-Hill; 2001. pp 1667–1724.
36. Nakanishi N, Ozawa K, Yamada S. Determination of NADPH-specific dihydropteridine reductase in extract from human, monkey, and bovine livers by single radial immunodiffusion: Selective assay differentiating NADPH- and NADH-specific enzymes. *J Biochem* 1986;99:1311–1315.
37. Lockyer J, Cook RG, Milstein S, Kaufman S, Woo SL, Ledley FD. Structure and expression of human dihydropteridine reductase. *Proc Natl Acad Sci USA* 1987;84:3329–3333.
38. Dahl HHM, Hutchinson W, McAdam W, Wake S, Morgan FJ, Cotton RG. Human dihydropteridine reductase: Characterization of a cDNA clone and its use in analysis of patients with dihydropteridine reductase deficiency. *Nucleic Acids Res* 1987;15:1921–1932.
39. Dahl HH, Wake S, Cotton RG, Danks DM. The use of restriction fragment length polymorphisms in prenatal diagnosis of dihydropteridine reductase deficiency. *J Med Genet* 1988;25:25–28.
40. Brown RM, Dahl HH. Localization of the human dihydropteridine reductase gene to band p15.3 of chromosome 4 by in situ hybridization. *Genomics* 1987;1:67–70.
41. Abelson HT, Gorka C, Beardsley GP. Identification of dihydropteridine reductase in human platelets. *Blood* 1979;53:116–121.
42. Shen RS, Abell CW. Purification of dihydropteridine reductase from human platelets. *J Neurosci Res* 1981;6:193.
43. Dianzani I, de Sanctis L, Smooker PM, Gough TJ, Alliaudi C, Brusco A, Spada M, Blau N, Dobos M, Zhang HP, Yang N, Ponzzone A, Armarego WL, Cotton RG. Dihydropteridine reductase deficiency: Physical structure of the *QDPR* gene, identification of two new mutations, and genotype–phenotype correlations. *Hum Mutat* 1998;12:267–273.
44. Ratnam S, Ratnam M, Cotton RG, Jennings IG, Freisheim JH. Anti-idiotypic antibodies elicited by pterin recognize active site epitopes in dihydrofolate reductases and dihydropteridine reductase. *Arch Biochem Biophys* 1989;275:344–353.

45. Dhondt JL. Tetrahydrobiopterin deficiencies. Lessons from the compilation of 200 patients. *Dev Brain Dysfunct* 1993;6:139–155.
46. Blau N, Thöny B, Spada M, Ponzone A. Tetrahydrobiopterin and inherited hyperphenylalaninemias. *Turk J Pediatr* 1996;38:19–35.
47. Smith I, Dhondt JL. Birthweight in patients with defective biopterin synthesis. *Lancet* 1985;1:813–818.
48. Blau N, Barnes I, Dhondt JL. International database of tetrahydrobiopterin deficiencies. *J Inher Metab Dis* 1996;19:8–14.
49. Longhi R, Valsasina R, Butte C, Paccanelli S, Riva E, Giovannini M. Cranial computerized tomography in dihydropteridine reductase deficiency. *J Inher Metab Dis* 1985;8:109–112.
50. Irons M, Levy HL, O'Flynn ME, Stack CV, Langlais PJ, Butler IJ, Milstien S, Kaufman S. Folinic acid therapy in treatment of dihydropteridine reductase deficiency. *J Pediatr* 1987;110:61–66.
51. Schmidt H, Ullrich K, Korinthenberg R, Peters PE. Basal ganglion calcification in hyperphenylalaninemia due to deficiency of dihydropteridine reductase. *Pediatr Radiol* 1988;19:54–56.
52. Woody RC, Brewster MA, Glazier C. Progressive intracranial calcification in dihydropteridine reductase deficiency prior to folinic acid therapy. *Neurology* 1989;39:673–675.
53. Coskun T, Besim A, Ozalp I, Erylimaz M. Intracranial calcification in dihydropteridine reductase deficiency. *Turk J Pediatr* 1990;32:259–264.
54. Blau N, Heizmann CW, Sperl W, Korenke GC, Hoffmann GF, Smooker PM, Cotton RGH. Atypical (mild) forms of dihydropteridine reductase deficiency: Neurochemical evaluation and mutation detection. *Pediatr Res* 1992;32:726–730.
55. Firgaira FA, Choo KH, Cotton RG, Danks DM. Heterogeneity of the molecular defect in human dihydropteridine reductase deficiency. *Biochem J* 1981;198:677–682.
56. Cotton RGH, Jennings I, Bracco G, Ponzone A, Guardamagna O. Tetrahydrobiopterin non-responsiveness in dihydropteridine reductase deficiency is associated with the presence of mutant protein. *J Inher Metab Dis* 1986;9:239–243.
57. Ponzone A, Guardamagna O, Ferraris S, Bracco G, Niederwieser A, Cotton RG. Two mutations of dihydropteridine reductase deficiency. *Arch Dis Child* 1988;63:154–157.
58. de Sanctis L, Alliaudi C, Spada M, Cerone R, Biasucci G, Blau N, Ponzone A, Dianzani I. Mutations and phenotypes in dihydropteridine reductase deficiency in Italy. *Pteridines* 1996;7:122–125.
59. Ponzone A, Ferrero GB, Guardamagna O, Ferraris S, Curtius HC, Blau N. Screening and treatment in tetrahydrobiopterin deficiency. In: Curtius HC, Ghisla S, Blau N, editors. *Chemistry and biology of pteridines*. Berlin: Walter de Gruyter; 1990. pp 393–401.
60. Dhondt JL. Strategy for the screening of tetrahydrobiopterin deficiency among hyperphenylalaninemic patients: 15-years experience. *J Inher Metab Dis* 1991;14:117–127.
61. Dianzani I, de Sanctis L, Spada M, Ponzone A. Genetic testing of hyperphenylalaninemias. *Min Biotech* 2000;12:71–82.
62. Danks DM, Cotton RG, Schlesinger P. Tetrahydrobiopterin treatment of variant form of phenylketonuria. *Lancet* 1975;2:1043.
63. Danks DM, Cotton RG, Schlesinger P. Variant forms of phenylketonuria. *Lancet* 1976;1:1236–1237.
64. Niederwieser A, Curtius HC, Viscontini M, Schaub J, Schmidt H. Phenylketonuria variants. *Lancet* 1979;1:550.
65. Curtius HC, Niederwieser A, Viscontini M, Otten A, Schaub J, Scheibenreiter S, Schmidt H. Atypical phenylketonuria due to tetrahydrobiopterin deficiency. Diagnosis and treatment with tetrahydrobiopterin, dihydrobiopterin, and sepiapterin. *Clin Chim Acta* 1979;93:251–262.
66. Niederwieser A, Curtius HC, Wang M, Leupold D. Atypical phenylketonuria with defective biopterin metabolism. Monotherapy with tetrahydrobiopterin or sepiapterin, screening and study of biosynthesis in man. *Eur J Pediatr* 1982;138:110–112.
67. Ponzone A, Guardamagna O, Ferraris S, Ferrero GB, Dianzani I, Cotton RG. Tetrahydrobiopterin loading test in hyperphenylalaninemia. *Pediatr Res* 1991;30:435–438.
68. Dhondt JL. Heterogeneity of tetrahydrobiopterin deficiency. In: Curtius HC, Blau N, Levine RA, editors. *Unconjugated pterins and related biogenic amines*. Berlin: Walter de Gruyter; 1987. pp 219–236.
69. Ponzone A, Guardamagna O, Ferraris S, Bracco G, Cotton RG. Screening for malignant phenylketonuria. *Lancet* 1987;28:512–513.
70. Endres W, Ibel H, Kierat L, Blau N, Curtius HC. Tetrahydrobiopterin and “non-responsive” dihydropteridine reductase deficiency. *Lancet* 1987;25:223.
71. Ponzone A, Guardamagna O, Spada M, Ferraris S, Ponzone R, Kierat L, Blau N. Differential diagnosis of hyperphenylalaninemia by a combined phenylalanine–tetrahydrobiopterin loading test. *Eur J Pediatr* 1993;152:655–661.

72. Ponzone A, Spada M, Ferrero GB, Ferraris S, Guardamagna O, Burlina AB, Blau N. Experience with the combined phenylalanine–tetrahydrobiopterin loading test in hyperphenylalaninemia. In: Farriaux P, Dhondt JL, editors. *New horizon in neonatal screening*. Amsterdam: Excerpta Medica; 1994. pp 115–120.
73. Ponzone A, Ferraris S, Spada M, Blau N, Piovon S, Burlina AB. Combined phenylalanine–tetrahydrobiopterin loading test in GTP cyclohydrolase 1 deficiency. *Eur J Pediatr* 1994;153:616.
74. Arai N, Narisawa K, Hayakawa H, Tada K. Hyperphenylalaninemia due to dihydropteridine reductase deficiency: Diagnosis by enzyme assays on dried blood spots. *Pediatrics* 1982;70:426–430.
75. Surplice IM, Griffiths PD, Green A, Leeming RJ. Dihydropteridine reductase activity in eluates from dried blood spots: Automation of an assay for a national screening service. *J Inher Metab Dis* 1990;13:169–177.
76. Narisawa K, Arai N, Ishizawa S, Ogasawara Y, Onuma A, Iinuma K, Tada K. Dihydropteridine reductase deficiency: Diagnosis by leukocyte enzyme assay. *Clin Chim Acta* 1980;105:335–342.
77. Firgaira FA, Cotton RG, Danks DM. Dihydropteridine reductase deficiency diagnosis by assays on peripheral blood cells. *Lancet* 1979;2:1260–1263.
78. Milstien S, Holtzman NA, O'Flynn ME, Thomas GH, Butler IJ, Kaufman S. Hyperphenylalaninemia due to dihydropteridine reductase deficiency. Assay of the enzyme in fibroblasts from affected infants, heterozygotes, and in normal amniotic fluid cells. *J Pediatr* 1976;89:763–766.
79. Nakabayashi H, Owada M, Kitagawa T. A mild case of dihydropteridine reductase deficiency with residual activity in erythrocytes. *J Inher Metab Dis* 1984;7:135–136.
80. Sahota AS, Leeming RJ, Blair JA, Armstrong RA, Green A, Cohen BE. Partial dihydropteridine reductase deficiency and mental retardation. *J Inher Metab Dis* 1986;9:247–249.
81. Niederwieser A, Curtius HC, Gitzelmann R, Otten A, Baerlocher K, Blehova B, Berlow S, Grobe H, Rey F, Schaub J, Scheibenreiter S, Schmidt H, Viscontini M. Excretion of pterins in phenylketonuria and phenylketonuria variants. *Helv Paediatr Acta* 1980;35:335–342.
82. Dhondt JL, Largillière C, Ardouin P, Farriaux JP, Dautrevaux M. Diagnosis of variants of hyperphenylalaninemia by determination of pterins in urine. *Clin Chim Acta* 1981;110:205–214.
83. Hyland K, Howells DW. Analysis and clinical significance of pterins. *J Chromatogr* 1988;429:95–121.
84. Narisawa K, Hayakawa H, Arai N, Matsuo N, Tanaka T, Naritomi K, Tada K. Diagnosis of variant forms of hyperphenylalaninemia using filter paper spots of urine. *J Pediatr* 1983;103:577–579.
85. Leeming RJ, Barford PA, Blair JA, Smith I. Blood spots on Guthrie cards can be used for inherited tetrahydrobiopterin deficiency screening in hyperphenylalaninaemic infants. *Arch Dis Child* 1984;59:58–61.
86. Blau N, Kierat L, Heizmann CW, Endres W, Giudici T, Wang M. Screening for tetrahydrobiopterin deficiency in newborns using dried urine on filter paper. *J Inher Metab Dis* 1992;15:402–404.
87. Leeming RJ, Hall SK, Surplice IM, Green A. Relationship between plasma and red cell biopterins in acute and chronic hyperphenylalaninaemia. *J Inher Metab Dis* 1990;13:883–887.
88. Ponzone A, Guardamagna O, Spada M, Ponzone R, Sartore M, Kierat L, Heizmann CW, Blau N. Hyperphenylalaninemia and pterin metabolism in serum and erythrocytes. *Clin Chim Acta* 1993;216:63–71.
89. Dhondt JL, Ardouin P, Hayte JM, Farriaux JP. Developmental aspects of pteridine metabolism and relationships with phenylalanine metabolism. *Clin Chim Acta* 1981;116:143–152.
90. Dhondt JL, Farriaux JP, Largillière C, Dautrevaux M, Ardouin P. Pterin metabolism in normal subjects and hyperphenylalaninaemic patients. *J Inher Metab Dis* 1981;4:47–48.
91. Wester P, Bergstrom U, Eriksson A, Gezelius C, Hardy J, Winbald G. Ventricular cerebrospinal fluid monoamine transmitter and metabolite concentrations reflect human brain neurochemistry in autopsy cases. *J Neurochem* 1990;54:1148–1156.
92. Hyland K. Abnormalities of biogenic amine metabolism. *J Inher Metab Dis* 1993;16:676–690.
93. Langlais PJ, Walsh FX, Bird ED, Levy HL. Cerebrospinal fluid neurotransmitter metabolites in neurologically normal infants and children. *Pediatrics* 1985;75:580–586.
94. Hyland K, Surtees R. Measurement of 5-methyltetrahydrofolate in cerebrospinal fluid using HPLC with coulometric electrochemical detection. *Pteridines* 1992;3:149–152.
95. Howells DW, Forrest SM, Dahl HH, Cotton RG. Insertion of an extra codon for threonine is a cause of dihydropteridine reductase deficiency. *Am J Hum Genet* 1990;47:279–285.
96. Smooker PM, Howells DW, Cotton RGH. Identification and in vitro expression of mutations causing dihydropteridine reductase deficiency. *Biochemistry* 1993;32:6443–6449.
97. Smooker PM, Cotton RGH. Molecular basis of dihydropteridine reductase deficiency. *Hum Mutat* 1995;5:279–284.
98. Smooker PM, Christodoulou J, McInnes RR, Cotton RG. A mutation causing dihydropteridine reductase deficiency results in a frameshift and secondary splicing defect. *J Med Genet* 1995;32:220–223.

99. Dianzani I, Howells DW, Ponzone A, Saleeba JA, Smooker PM, Cotton RG. Two new mutations in the dihydropteridine reductase gene in patients with tetrahydrobiopterin deficiency. *J Med Genet* 1993;30:465–469.
100. Ikeda H, Matsubara Y, Mikami H, Kure S, Owada M, Gough T, Smooker PM, Dobos M, Dahl HHM, Cotton RGH, Narisawa K. Molecular analysis of dihydropteridine reductase deficiency: Identification of two novel mutations in Japanese patients. *Hum Genet* 1997;100:637–642.
101. Smooker PM, Gough TJ, Cotton RGH, Alliaudi C, de Sanctis L, Dianzani I. A series of mutations in the dihydropteridine reductase gene resulting in either abnormal RNA splicing or DHPR protein defects. *Hum Mutat* 1999;13:503–504.
102. Zhang H-P, Yang N, Armarego WLF. In vitro mutagenesis of human dihydropteridine reductase at the active site and at altered sites found in the reductase of deficient children. *Pteridines* 1996;7:126–136.
103. Yershov G, Barsky V, Belgovskiy A, Kirillov E. DNA analysis and diagnostics on oligonucleotide microchips. *Proc Natl Acad Sci USA* 1996;93:4913–4918.
104. McKenzie SE, Mansfield E, Rappaport E, Surrey S, Fortina P. Parallel molecular genetic analysis. *Eur J Hum Genet* 1998;6:417–429.
105. Fortina P. Applications of emerging technologies to the study of human genetics. *Eur J Hum Genet* 1998;6:2–3.
106. Ferraris S, Guardamagna O, Bracco G, Ponzone A. Trial of indirect screening of tetrahydrobiopterin deficiency. *Pediatr* 1987;42:549–555.
107. Lou HC, Guttler F, Likkellund C, Brunh P, Niederwieser A. Decreased vigilance and neurotransmitter synthesis after discontinuation of dietary treatment for phenylketonuria in adolescents. *Eur J Pediatr* 1985;144:17–20.
108. Ponzone A, Guardamagna O, Ferraris S, Biasetti S, Bracco G, Niederwieser A. Neurotransmitter therapy and diet in malignant phenylketonuria. *Eur J Pediatr* 1987;146:93–94.
109. Ferraris S, Guardamagna O, Bonetti G, Bracco G, Ponzone A, Niederwieser A. Fate of peripherally administered tetrahydrobiopterin in congenital deficiency. In: Curtius HC, Blau N, Levine RA, editors. *Unconjugated pteridines and related biogenic amines*. Berlin: Walter de Gruyter; 1987. pp 284–292.
110. Kaufman S. Pterin administration as a therapy for PKU due to dihydropteridine-reductase deficiency? *Lancet* 1975;2:767.
111. Kaufman S. Hyperphenylalaninemia caused by defects in biopterin metabolism. *J Inher Metab Dis* 1985;8:20–27.
112. Kaufman S. Unsolved problems in diagnosis and therapy of hyperphenylalaninemia caused by defects in tetrahydrobiopterin metabolism. *J Pediatr* 1986;109:572–578.
113. Spada M, Blau N, Meli C, Ferrero GB, de Sanctis L, Ferraris S, Ponzone A. Different strategies in the treatment of dihydropteridine reductase deficiency. *Pteridines* 1996;7:107–111.
114. Kapatos G, Kaufman S. Peripherally administered reduced pterins do enter the brain. *Science* 1981;212:955–956.
115. Ponzone A, Biasetti S, Ferraris S, Guardamagna O, Curtius HC, Kierat L, Blau N. Differential entrance of tetrahydrobiopterin into the brain of patients with 6-pyruvoyl tetrahydropterin synthase deficiency. In: Levine RA, Milstein S, Kuhn DM, Curtius HC, editors. *Pterins and biogenic amines in neuropsychiatry, pediatrics, and immunology*. Grosse Point: Lakeshore Publ. Co; 1989. pp 325–334.
116. Bartholomé K, Byrd D. L-dopa and 5-hydroxytryptophan therapy in phenylketonuria with normal phenylalanine-hydroxylase activity. *Lancet* 1975;2:1042–1043.
117. Ponzone A, Biasetti S, Guardamagna O, Ferraris S. Terapia dei difetti di tetraidrobiopterina. In: Nicola P, Ponzone A, Cerutti F, editors. *Juvenile diabetes, hyperammoniemi, hyperphenylalaninemi*. Milan: Masson S.p.A.; 1988. pp 275–284.
118. Spada M, Parrella T, Ponzone R, Ferraris S, Guardamagna O, Ponzone A, Blau N. Monitoring treatment in tetrahydrobiopterin deficiency. *Pteridines* 1992;3:13–15.
119. Hyland K, Surtees RAH, Heales SJR, Bowron A, Howells DW, Smith I. Cerebrospinal fluid concentrations of pterins and metabolites of serotonin and dopamine in a pediatric reference population. *Pediatr Res* 1993;34:10–14.
120. Allen RJ, Young W, Bonacci J, Persico S, Andruszewsky K, Schaefer AM. Neonatal dystonic parkinsonism, a “stiff baby syndrome”, in biopterin deficiency with hyperprolactinemia, and responsiveness to treatment. *Ann Neurol* 1990;28:434–437.
121. Spada M, Ferraris S, Ferrero GB, Sartore M, Lanza C, Perfetto F, de Sanctis L, Dompe C, Blau N, Ponzone A. Monitoring treatment in tetrahydrobiopterin deficiency by serum prolactin. *J Inher Metab Dis* 1996;19:231–233.

122. Birnbacher R, Scheibenreiter S, Blau N, Bieglmayer C, Frisch H, Waldhauser F. Hyperprolactinemia, a tool in treatment control of tetrahydrobiopterin deficiency: Endocrine studies in an affected girl. *Pediatr Res* 1998;43:472–477.
123. Tanaka Y, Matsuo N, Tsuzac S, Araki K, Tsuchiya Y, Niederwieser A. On–off phenomenon in a child with tetrahydrobiopterin deficiency due to 6-pyruvoyl tetrahydropterin synthase deficiency (BH4 deficiency). *Eur J Pediatr* 1989;148:450–452.
124. Harpey JP. Biopterin synthesis defects: Complete deficiencies (reductase and synthetase). *Arch Fr Pediatr* 1983;40:231–235.
125. Schuler A, Blau N, Ponzzone A. Monoamine oxidase inhibitors in tetrahydrobiopterin deficiency. *Eur J Pediatr* 1995;154:997.
126. Spada M, Schuler A, Blau N, Ferraris S, Lanza C, Ponzzone A. Deprenyl in 6-pyruvoyl tetrahydropterin synthase deficiency. *Pteridines* 1995;6:144–148.
127. Grandas F, Lopez-Ariztegui N. Physiopathology of the dyskinesias induced by L-dopa. *Rev Neurol* 1997;25:151–156.
128. Nutt JG. Catechol-*O*-methyltransferase inhibitors for treatment of Parkinson's disease. *Lancet* 1998;351:1221–1222.
129. Ponzzone A, Baglieri S, Battistoni G, Martini A, Spada M. COMT inhibitors in the treatment of tetrahydrobiopterin deficiency. *Pteridines* 2001;12:70.
130. Ponzzone A, Baglieri S, Battistoni G, Peduto A, Giovannozzi C, Valenzise M, Ferraris S, Martini A, Spada M. Catechol-*O*-methyltransferase inhibition in the treatment of tetrahydrobiopterin deficiency. In: Milstien S, Kapatos G, Levine RA, Shane B, editors. *Chemistry and biology of pteridines and folates*. Boston: Kluwer Acad. Publ.; 2002. pp 319–328.
131. Smith I, Hyland K, Kendall B. Clinical role of pteridine therapy in tetrahydrobiopterin deficiency. *J Inher Metab Dis* 1985;8:39–45.
132. Dhondt JL. Tetrahydrobiopterin deficiencies. Preliminary analysis from an international survey. *J Pediatr* 1984;104:501–508.
133. Al-Aqeel A, Ozand PT, Gascon G, Nester M, al Nasser M, Brismar J, Blau N, Hughes H, Subramanyan SB, Reynolds CT. Biopterin-dependent hyperphenylalaninemia due to deficiency of 6-pyruvoyl tetrahydropterin synthase. *Neurology* 1991;41:730–737.
134. Coskun T, Ozalp I, Tokatli A, Blau N, Niederwieser A. Hyperphenylalaninemia due to tetrahydrobiopterin deficiency. *J Inher Metab Dis* 1993;16:605–607.
135. Hsiao KJ, Chiang SH, Liu TT, Chiu PC, Wu KF. Tetrahydrobiopterin deficient phenylketonuria detected by neonatal screening in Taiwan. In: Curtius HC, Ghisla S, Blau N, editors. *Chemistry and biology of pteridines*. Berlin: Walter de Gruyter; 1990. pp 402–407.
136. Ponzzone A, Ricca V, Ferraris S, Guardamagna O, Bracco G, Pagliardini S, Levis F, Giovannini M, Riva E, Longhi R. DHPR deficiency in Italy. *J Pediatr* 1984;105:1008.
137. Bracco G, Iavarone A, Pagliardini S, Levis F, Guardamagna O, Ferraris S, Ponzzone A. Dihydropteridine reductase activity in fetal tissues. In: Curtius HC, Blau N, Levine RA, editors. *Unconjugated pterins and related biogenic amines*. Berlin: Walter de Gruyter; 1987. pp 265–267.
138. Dhondt JL, Hayte JM, Forzy G, Delcroix M, Farriaux JP. Unconjugated pteridines in amniotic fluid during gestation. *Clin Chim Acta* 1986;161:269–273.
139. Ponzzone A, Ferraris S, Biasetti S, Dianzani I, Guardamagna O, Kierat L, Niederwieser A. Placental barrier in mother-to-fetus transfer of tetrahydrobiopterin in humans. In: Curtius HC, Blau N, Levine RA, editors. *Unconjugated pterins and related biogenic amines*. Berlin: Walter de Gruyter; 1987. pp 303–308.
140. Dhondt JL, Tilmont P, Ringel J, Farriaux JP. Pterins analysis in amniotic fluid for the prenatal diagnosis of GTP cyclohydrolase deficiency. *J Inher Metab Dis* 1990;13:879–882.
141. Ferrè J, Naylor EW. Sepiapterin reductase in human amniotic and skin fibroblasts, chorionic villi, and various blood fractions. *Clin Chim Acta* 1988;174:271–282.
142. Ponzzone A, Dianzani I, Spada M, de Sanctis L, Guardamagna O, Viora E, Ponzzone R, Kierat L, Leimbacher W, Matasovic A, Blau N. Prenatal diagnosis in primary hyperphenylalaninemias. *Dev Brain Dysf* 1993;6:158–161.
143. Blau N, Kierat L, Matasovic A, Leimbacher W, Heizmann CW, Guardamagna O, Ponzzone A. Antenatal diagnosis of tetrahydrobiopterin deficiency by quantification of pterins in amniotic fluid and enzyme activity in fetal and extrafetal tissue. *Clin Chim Acta* 1994;226:159–164.
144. Kalkanoglu HS, Romstad A, Coskun T, Guttler F. Evaluation of a fetus at risk for dihydropteridine reductase deficiency by direct mutation analysis using denaturing gradient gel electrophoresis. *Prenat Diagn* 2001;21:868–870.

145. Romstad A, Kalkanoglu HS, Coskun T, Demirkol M, Tokatli A, Dursun A, Baykal T, Ozalp I, Guldberg P, Guttler F. Molecular analysis of 16 Turkish families with DHPH deficiency using denaturing gradient gel electrophoresis (DGGE). *Hum Genet* 2000;107:546–553.

Alberto Ponzone graduated in Medicine in 1959 and specialized in Pediatrics in 1961 at the University of Torino, Italy. At the Department of Pediatrics of the same University he was appointed Assistant Professor in 1962, qualified for University teaching of Puericulture in 1966 and of Pediatrics in 1967, Consultant in hematology and immunology (1964–1968), neonatology (1969–1973), general pediatrics (1974–1981), nutrition and metabolism (1982–1987), creating and developing a clinical center and a laboratory devoted to the care, and to the study of inborn errors of metabolism. Full Professor since 1988, he had the Chair of Pediatrics at the University of Sassari (1992), Messina (1995), and Torino (1998), where he is currently the Chairman of the 1st Pediatric Clinic. During the last 20 years, his broad research interests concerned different inherited disorders of metabolism, including phenylketonuria, tetrahydrobiopterin deficiency, cystinuria.

Marco Spada graduated in Medicine in 1990 and specialized in Pediatrics in 1994 at the University of Torino, Italy. Visiting Scientist (1991–1994) at the Service of Medical Genetics, Metabolic Unit, Hôpital Necker des Enfants Malades, Paris, he received his PhD in Pediatric Sciences at the University of Torino. In 1994, he was appointed Assistant Professor of Pediatrics and in 1997 Consultant in metabolic diseases at the Department of Pediatrics of the same University, where he is currently professor at the Postgraduate Schools of Genetics and of Pediatrics. His scientific interests cover, besides hyperphenylalaninemia, a large spectrum of inborn errors of metabolism, including lysosomal diseases, hyperinsulinism, CDG syndromes, and peroxisomal disorders.

Silvio Ferraris graduated in Medicine in 1979 and specialized in Pediatrics in 1983 at the University of Torino, Italy. In 1987, he was appointed Assistant Professor and in 1992 Consultant in general pediatrics and neonatology at the Department of Pediatrics of the same University. He is currently professor at the Postgraduate School of Clinical Pathology of the University of Torino, with main research interests in primary hyperphenylalaninemia and mitochondrial diseases.

Irma Dianzani graduated in Medicine at the University of Torino, Italy, in 1982, and specialized in Pediatrics at the same University in 1986. She worked at the Murdoch Institute, Melbourne, Australia, in 1989–1990 as visiting scientist, and received her PhD in Biochemistry and Biology at the Brunel University, Uxbridge, UK, in 1991. She worked at the University of Torino, Department of Pediatrics, as Research Officer from 1985 to 1998. In 1998, she was appointed Associate Professor in General Pathology at the University of Piemonte Orientale, Faculty of Sciences, and in 2001 full Professor at the same University. Her chief research interests concern molecular and functional genetics of mendelian diseases, including hyperphenylalaninemia.

Luisa de Sanctis graduated in Medicine at the University of Torino, Italy, in 1992 and specialized in Pediatrics at the same University in 1996. She received her PhD in Pediatric Sciences at Federico II University, Naples, Italy, in 2000. Since 1997, she has been working at the Department of Pediatrics, University of Torino, as Consultant in neonatology, with main research interests in the molecular genetics of hyperphenylalaninemia, cystinuria, and Gs α protein disorders.